

NOTES: 1) INTERNAL 2000 LINE ENCODER, 8000 COUNTS PER REVOLUTION
INDEX LINE ON ENCODER WHEEL
2) MATING CONNCTOR IS A HIGH DENSITY 26 PIN FEMALE D-SUB CONNECTOR
NORCOMP PART# 180-026-202-001 (SOLDER CUP CONNECTION) OR SIMILAR.
3) DIMENSIONS ARE NOMINAL UNLESS OTHERWISE INDICATED.
4) RECOMMENDED MOUNTING SCREW SIZE #10, HEAD DIA IS 0.360 MAX.

PART NO
ST34X000000000

DRAWING REVISIONS		
DWG REV	DESCRIPTION	DATE
1	Initial Drawing Release	04/28/04
2	REVISE OUTPUT Bo, Bt, and BRK. PART# changed	03/09/05

INPUT OUTPUTS PINS			
PIN#	NAME	FUNCTION	DESCRIPTION
1	IO A	DIGITAL I/O	5V TTL, INPUT: SINK 5mA/OUTPUT: SINK 10mA, SOURCE 5mA
		ANALOG IN	SINKING INPUT, 0 TO 5VDC 10-BIT RESOLUTION
2	IO B	DIGITAL I/O	5V TTL, INPUT: SINK 5mA/OUTPUT: SINK 10mA, SOURCE 5mA
		ANALOG IN	SINKING INPUT, 0 TO 5VDC 10-BIT RESOLUTION
3	IO C	LIMIT INPUT (POSITIVE DIRECTION)	SINKING INPUT 5mA, TRIGGER HIGH DIRECTIONAL LIMIT
		DIGITAL I/O	5V TTL, INPUT: SINK 5mA/OUTPUT: SINK 10mA, SOURCE 5mA
4	IO D	ANALOG IN	SINKING INPUT, 0 TO 5Vdc 10-BIT RESOLUTION
		LIMIT INPUT (NEGATIVE DIRECTION)	SINKING INPUT 5mA, TRIGGER HIGH DIRECTIONAL LIMIT
5	IO E	DIGITAL I/O	5V TTL, INPUT: SINK 5mA/OUTPUT: SINK 10mA, SOURCE 5mA
		ANALOG IN	SINKING INPUT, 0 TO 5VDC 10-BIT RESOLUTION
6	IO F	DIGITAL I/O	5V TTL, INPUT: SINK 5mA/OUTPUT: SINK 10mA, SOURCE 5mA
		ANALOG IN	SINKING INPUT, 0 TO 5VDC 10-BIT RESOLUTION
7	IO G	GD-SYNCHRONIZATION	5V-TTL, INPUT: SINK 5mA "G" COMMAND ISSUED WHEN PIN IS SINKED
		GOSUB2 ON INTERRUPT	GOES TO SUBROUTINE C2 WHEN PIN IS TRIGGERED AND IF COMMAND F=64 IS ISSUED. 5V-TTL, INPUT: SINK 5mA
		DIGITAL I/O	5V-TTL, INPUT: SINK 5mA OUTPUT: SINK 10mA, SOURCE 5mA
		ANALOG IN	SINKING INPUT, 0 TO 5Vdc 10-BIT RESOLUTION
14	BRK	BRK OUTPUT	BRAKE SIGNAL, SINKING OUTPUT ONLY, SINK 300mA (MAX) DRIVES TO GND TO ENGAGE BRAKE
15	Bt	Bt OUTPUT	TRAJECTORY SIGNAL, SINKING OUTPUT ONLY, SINK 100mA (MAX) DRIVES TO GND WHEN NON-TRAJECTORY (Bt IS 0)
16	5Vdc	+5VDC OUT	+5VDC REFERENCED TO TTL I/O. MAX LOAD: 200 mA
23	Bo	Bo OUTPUT	Bo SIGNAL, SINKING OUTPUT ONLY, SINK 100mA (MAX) DRIVES TO GND WHEN AMPLIFIER IS ON, Bo IS 0
24	Pc	CONTROL PWR	CONTROL POWER INPUT (20-35VDC)
8	GND	GROUND INPUT (RETURN)	MAIN GROUND (INTERNALLY CONNECTED PINS 8, 17 AND 25)

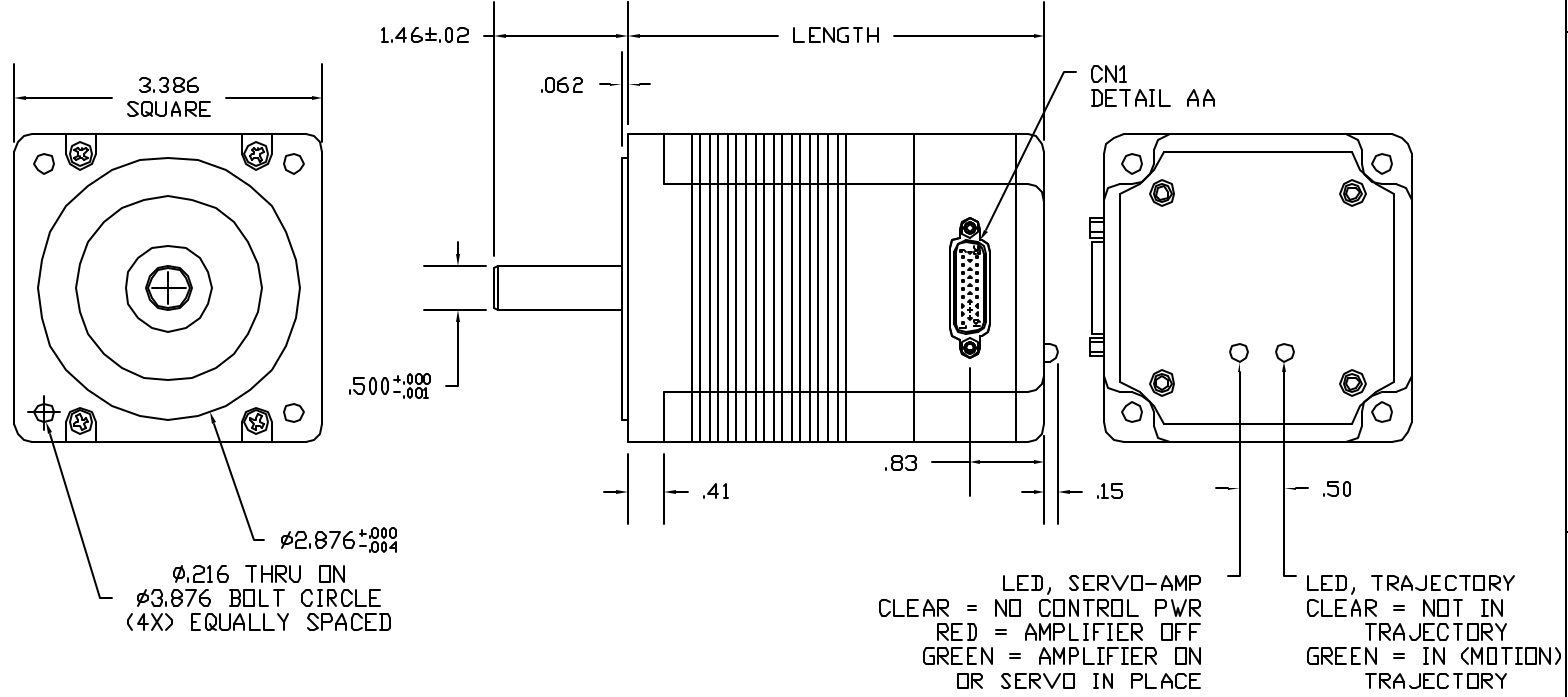

SPECIFICATION	UNITS	MODEL		
		ST341000000000	ST342000000000	ST343000000000
Continuous Torque	oz-in	372	727	1105
Peak Torque	oz-in	372	789	1133
Power	Hp	0.131	0.155	0.139
No Load Speed	rpm	1600	1600	1500
Encoder Resolution	Counts	8000	8000	8000
Rotor Inertia	oz-in-sec ²	0.0226	0.0481	0.0707
Weight	LB	6.2	9.7	13.2
Length	in	5.0	6.5	8.0
Thermal Limit	*C	85	85	85

CN1: POWER, COMMUNICATION AND IO CONNECTOR MALE, HI-DENSITY 26PIN D-SUB, SHELL SIZE 2

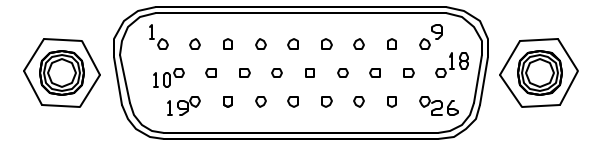

COMMUNICATION AND ENCODER PINS			
10	ENC A	ENC A IN	SINKING INPUT 10mA (ISOLATED)
		STEP INPUT	MAX FREQUENCY IS 2MHz WITH 500 OHM IMPEDANCE
11	ENC B	ENC B IN	SINKING INPUT 10mA (ISOLATED)
		DIR INPUT	MAX FREQUENCY IS 2MHz WITH 500 OHM IMPEDANCE
13	RS485 A	RS485 A	RS-485-A (ISOLATED)
21	RS485 B	RS485 B	RS-485-B (ISOLATED)
19	ENC A OUT	ENC A OUT	ENCODER A OUTPUT (ISOLATED)
20	ENC B OUT	ENC B OUT	ENCODER B OUTPUT (ISOLATED)
12	GND (ISO)	GND (ISO)	ISOLATED GROUND REF. (COMMON GROUND FOR RS485 ANC ENC SIGNAL)
22	5Vdc (ISO)	5Vdc (ISO)	+5VDC REF. (ISOLATED) MAX LOAD 40mAMPS

Power			
9	PWR	AMPLIFIER POWER INPUT	AMPLIFIER POWER INPUT (20-85VDC)
18		AMPLIFIER POWER INPUT	
26	GND	GROUND INPUT (RETURN)	MAIN GROUND (INTERNALLY CONNECTED PINS 8, 17 AND 25)
8		GROUND INPUT (RETURN)	
17		GROUND INPUT (RETURN)	
25			

ITEM NO	QTY	PART NO	DESCRIPTION	MATERIAL SPECIFICATION
PARTS LIST				
UNLESS OTHERWISE SPECIFIED, DIMENSIONS & TOLERANCES ARE PER ANSI Y14.5M AND ARE IN INCHES. TOLERANCES ARE AS FOLLOWS: DECIMALS .XX±.01 ANGLES ± ANGTOL XXX±.005 .XXX±.XXX				
MATERIAL NA		DRAWN MT		DATE 04/28/04
FINISH NA		SCALE NA		
			Animatics Corporation	
SERVO_STEP ST34X000000000				
SIZE B	COMPUTER GENERATED DRAWING	PART NO. ST34X000000000	DWG REV 2	
SIMILAR TO: NA	CAD FILE NAME ST34	SHEET 1_OF_1		

CONFIDENTIAL. THE INFORMATION CONTAINED HEREIN IS THE PROPRIETARY PROPERTY OF ANIMATICS CORPORATION, AND IS PROTECTED AS A TRADE SECRET. IT IS SUBMITTED FOR USE BY RECIPIENT ONLY FOR A BUSINESS PURPOSE AUTHORIZED BY ANIMATICS CORPORATION. ANY OTHER USE IS PROHIBITED. RECIPIENT AGREES TO KEEP SUCH INFORMATION CONFIDENTIAL.